

# KONSOLEN/SCHALLSCHUTZ BRACKETS / SOUND PROTECTION

Preise in **SCHWARZ** = Lagerware, **ROT** = Bestellware (kurzfristig lieferbar !)

Prices in **BLACK** = on stock, **RED** = on order (short delivery time !)

## Konsolenset Schallgedämmt

Bracket set with sound absorber

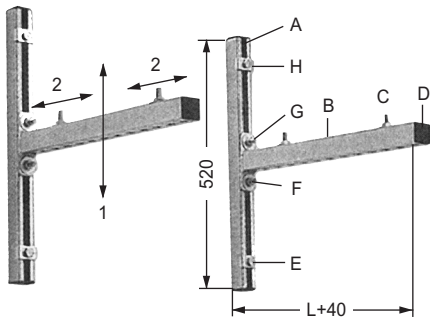

- A 2 Stk. Systemschienen System bars
- B 2 Stk. Schienenkonsolen Bracket bars
- C 4 Stk. Silentblöcke Dampers
- D 6 Stk. Abschlusskappen End caps
- 4 Stk. Hammerkopfschrauben M10/30  
Hammer head screws M10/30
- E 4 Stk. U-Scheiben U-washers
- F 4 Stk. Sechskantschrauben M8x20  
Hexagon head screws M8x20
- H 4 Stk. Halteklammern M8 retaining clamps

### Einstellungen / Adjustments

- 1 Höhe height
- 2 Vor-Rückwärts front-rear
- 3 rechts- links mittels right-left

### Zubehör

4 **Systemschienen 38/40 EURO** --,-- Länge 2m  
dient zusätzlich als Querverbindung und wird auf den  
gewünschten Konsolenabstand zugeschnitten (2 Stk.)

X **Silentblöcke**

NEU ! 4 Stk Puffer M8 30x30 Ø reduzieren den  
Körperschall um bis zu 17dB(A)

NEW ! 4 pcs Damper M8 30x30 Ø decrease the  
mechanical vibration up to 17dB(A)

Profil	Länge Length	Euro	Stk.
<b>Konsolenset</b>	<b>SD 38/40-480 mm</b>	<b>Euro</b>	<b>--,--</b>
<b>Bracket set</b>	<b>" -560 mm</b>	<b>Euro</b>	<b>--,--</b>
	<b>" -640 mm</b>	<b>Euro</b>	<b>--,--</b>

## Wichtig! Querverstrebung

Important! Cross connection

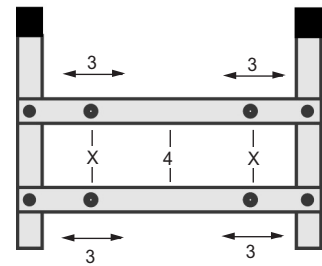

### Accessories

4 **Systembars 38/40** Length 2m for additional cross  
connection - adjusted to the required distance of the  
brackets (2 Stk.)

X **Silentdamper**

## Systemschiene 38/40

Systembar 38/40

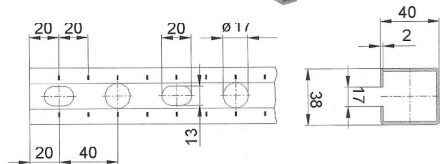
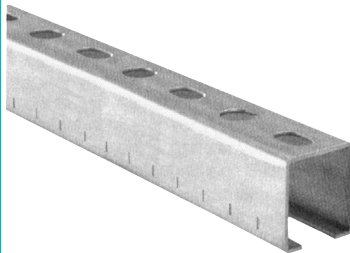

In Verbindung mit Systembauteilen als Trägerkonstruktion  
von Lüftungskanälen, Ventilatoren, Kompaktanlagen usw.  
Together with system parts used as bracket constr. for ventila-  
tion ducts, fans, fan-units, etc

**Systemschiene 38/40 L=2m** Euro --,--

## Konsolen/Stützenstreben 38/40

Mount. brackets/Support bracket. 38/40

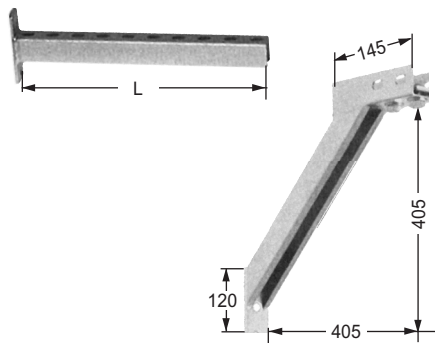

<b>Konsolen 38/40 Länge 320</b>	<b>Euro</b>	<b>--,--</b>
<b>Brackets</b>	<b>" -560</b>	<b>Euro</b>
<b>"</b>	<b>" -640</b>	<b>Euro</b>
<b>"</b>	<b>" -800</b>	<b>Euro</b>
<b>Stützstrebe Support bracket 38/40</b>	<b>Euro</b>	<b>--,--</b>

## Montagewinkel 38/40

Mounting angles 38/40

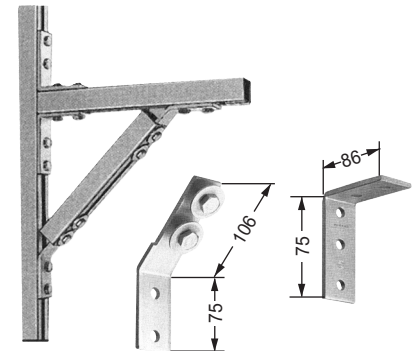

<b>Montagewinkel 38/40 45°</b>	<b>1 Stk. Euro</b>	<b>--,--</b>
<b>Mountingangle</b>	<b>25 Stk. Euro</b>	<b>--,--</b>
<b>Montagewinkel 38/40 90°</b>	<b>1 Stk. Euro</b>	<b>--,--</b>
<b>Mountingangle</b>	<b>25 Stk. Euro</b>	<b>--,--</b>

## Vario Sattelflansch

Vario bridge flange

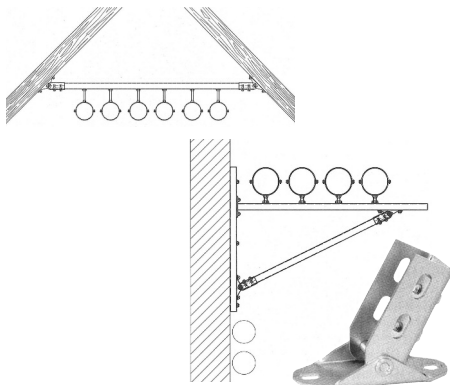

<b>Vario Sattelflansch 38/40</b>	<b>1 Stk. Euro</b>	<b>--,--</b>
<b>minimaler Winkel 20°</b>	<b>4 Stk. Euro</b>	<b>--,--</b>
<b>Vario bridge flange 38/40</b>		
<b>minimum angle 20°</b>		

## Sattelflansch

Bridge flange

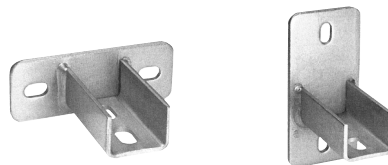

<b>Sattelflansch 38/40 Quer</b>	<b>1 Stk. Euro</b>	<b>--,--</b>
<b>Bridge flange 38/40 cross</b>	<b>25 Stk. Euro</b>	<b>--,--</b>
<b>Sattelflansch 38/40 Längs</b>	<b>1 Stk. Euro</b>	<b>--,--</b>
<b>Bridge flange 38/40 along</b>	<b>25 Stk. Euro</b>	<b>--,--</b>

## Verbindungsplatten

Connection plates

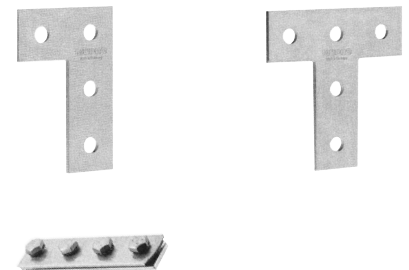

<b>Winkelplatten 38/40- 90°</b>	<b>1Stk.€--,--</b>	<b>25Stk. € --,--</b>
<b>Angleplate 38/40 - 90°</b>		
<b>T-Platten T-plate 38/40</b>	<b>1Stk.€--,--</b>	<b>25Stk. € --,--</b>
<b>Schienenverbinder 38/40</b>	<b>1Stk.€--,--</b>	<b>25Stk. € --,--</b>
<b>Bar connector 38/40</b>		

**Befestigung Mounting**



**Halteklammer 38/40 / Fixing plate**

<b>M8</b>	1 Stk.	€ -,-	100 Stk.	€ -,-
<b>M10</b>	"	€ -,-	"	€ -,-

**Schiebemutter 38/40 / Sliding nut**

<b>38/40 M 8</b>	1 Stk.	€ -,-	100 Stk.	€ -,-
<b>38/40 M10</b>	"	€ -,-	"	€ -,-

**Mutter / Nut**

<b>M 8</b>	1 Stk.	€ -,-	100 Stk.	€ -,-
<b>M10</b>	"	€ -,-	"	€ -,-
<b>M12</b>	"	€ -,-	"	€ -,-

**Schrauben / Screws**

<b>M10x25</b>	1 Stk.	€ -,-	100 Stk.	€ -,-
" <b>x35</b>	"	€ -,-	"	€ -,-
" <b>x60</b>	"	€ -,-	"	€ -,-

**Schrauben / Screws**

<b>M8x25</b>	1 Stk.	€ -,-	100 Stk.	€ -,-
" <b>x35</b>	"	€ -,-	"	€ -,-
" <b>x60</b>	"	€ -,-	"	€ -,-

**Unterlagsscheiben / Flat washer**

<b>M 8/24Ø/2</b>	1 Stk.	€ -,-	100 Stk.	€ -,-
<b>M10/36Ø/2</b>	"	€ -,-	"	€ -,-
<b>M12/ " Ø/2</b>	"	€ -,-	"	€ -,-

**Beilagsscheiben / Washer**

<b>M 8/16Ø/1,6</b>	1 Stk.	€ -,-	100 Stk.	€ -,-
<b>M10/20Ø/2,0</b>	"	€ -,-	"	€ -,-
<b>M12/24Ø/2,5</b>	"	€ -,-	"	€ -,-

**Abschlusskappe 38/40 Protection cap**

<b>38/40</b>	1 Stk.	€ -,-	100 Stk.	€ -,-
--------------	--------	-------	----------	-------

**Gummiprofil Rubber profile**

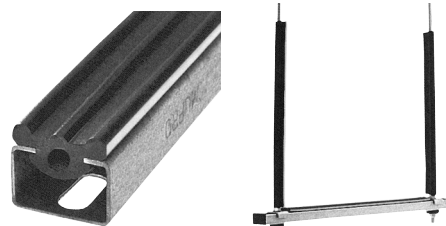

Montagebeispiel mounting example

Verhindert Flatter- und Vibrationsgeräusche.  
Prevents knocking and vibration sounds

<b>Gummiprofil 38/40</b> Rubber profile	Rolle 30m	€ -,-
<b>Gummiprofilzuschnitte</b> Rubber profile parts <b>38/40-50mm</b>	25 Stk.	€ -,-
	100 Stk.	€ -,-

**Körperschallentkopplung Structure borne sound decoupling**

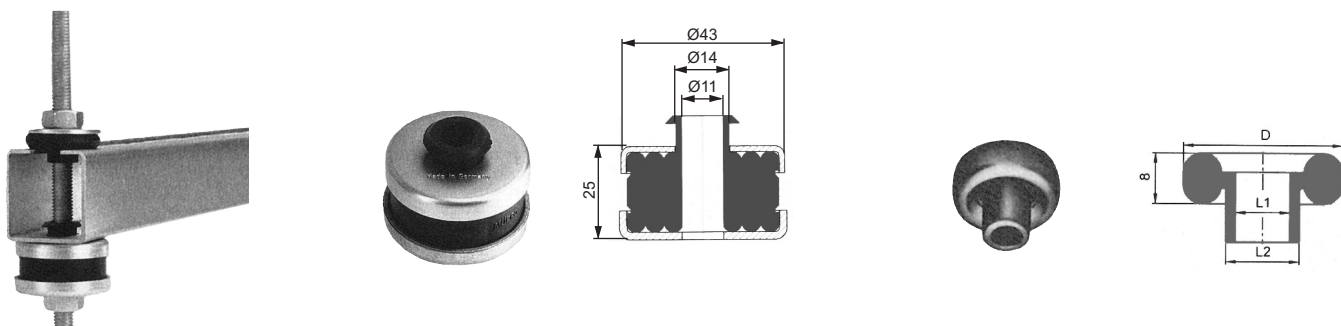

Anwendung für viele Montagesituationen. Schutzröhre gegen Kantenberührung. Schallverbesserung ca. 17 dB.  
Application for many mounting situations. Guard ring against direct contact. Sound level reduction approx. 17dB

Für Traversen und Rohrbrücken.  
For crossbars and pipe racks.

<b>Puffer M8/M10</b> Anti vibration mount	1 Stk.	Euro -,-
	100 Stk.	Euro -,-

100 - 450 kg max.

Für Schrauben und Gewindestifte. For screws and threaded studs

<b>Pufferscheibe M8/24</b> Anti vibration washer	1 Stk.	Euro -,-
" " <b>M10/34</b>	100 Stk.	Euro -,-
	1 Stk.	Euro -,-
	100 Stk.	Euro -,-

3 kg max.

**Schwingungsdämpfer Anti vibration mount**

**Abb. 1** Druckelement (Puffer)  
Compression element

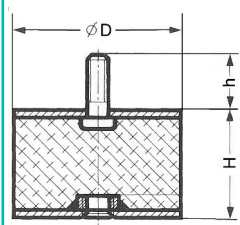

**Abb. 2** Druckelement (Hut)  
Compression element

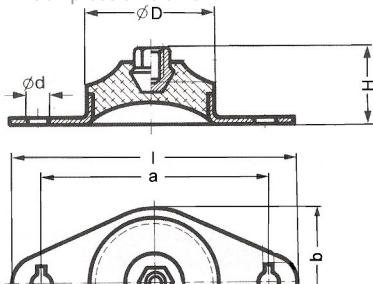

**Abb. 3** Zug/Druckelement (Glocke)  
Tensile-/Compression element

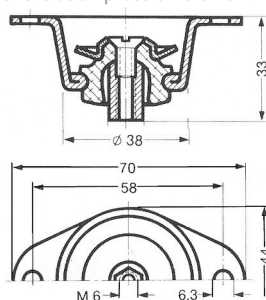

**Abb.1** Puffer mit ein oder beidseitigen Aussengewinde.  
Anti vibration mount with single or double outer thread

<b>25-30-2M6 55</b>	Shore 5-25 kg	4 Stk.	€ -,-
<b>30-30-2M8 55</b>	" 10-40 kg	4 Stk.	€ -,-

**Abb.2** Hutelement / Hat element

<b>27860 M6 65</b>	" 2,5-25 kg	4 Stk.	€ -,-
<b>27859 M10 55</b>	" 5-35 kg	4 Stk.	€ -,-
<b>M8 60 SH-3080</b>	" 30-80 kg	1 Stk.	€ -,-
<b>M8 60 SH-50120</b>	" 50-120 kg	1 Stk.	€ -,-

**Abb.3** Glockenelement. / Bell element

<b>58500 M6/M8 65</b>	Shore 2-20 kg	4 Stk.	€ -,-
-----------------------	---------------	--------	-------

Abmessungen	H	h	DØ	b	l	Ød	a
<b>25-30-2/55</b>	30	18	25	-	-	8/10	-
<b>30-30-2/55</b>	"	20	30	-	-	-	-
<b>27860 -55</b>	20	-	30	35	60	6	45
<b>27859 -55</b>	32	-	45	50	90	9	70
<b>M8 60 SH-3080</b>	25	-	40	55	90	9	67
<b>M8 60 SH-50120</b>	35	-	50	55	90	9	67

**Federschwingungsdämpfer m. Platte Spring anti vibration mount w. plate**

**NEU**

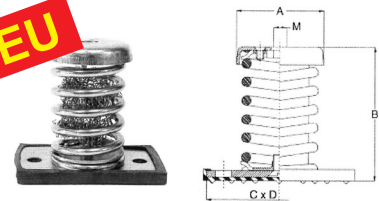

Anwendung für sämtliche Ventilatoren (für Brandgasventilatoren Vorschrift !). Können auch für große Klimageräte verwendet werden.

Application for all fans (technical regulation for smoke extract fans !). Special application also for big air-conditioners.

Type	Belastung	Abmessungen				Preis
M		A	B	C	D	€/Stk
<b>M8 - 25</b>	10- 25kg	54	80	90	55	-,-
<b>M8 - 50</b>	20- 50kg	54	80	90	55	-,-
<b>M8 - 75</b>	30- 75kg	54	80	90	55	-,-
<b>M8 -100</b>	45-110kg	54	80	90	55	-,-
<b>M12-150</b>	60-150kg	70	120	110	75	-,-